

BUTTERFLY VALVE WAFER

TECHNICAL FEATURES

- SIZE: FROM DN 20 A DN 1200 (3/4"-48")
- UPPER FLANGE: EN ISO 5211
- TEMPERATURE: - 20°C + 160°C (DEPENDING ON WORKING PRESSURE AND MATERIALS)
- DIFFERENTIAL PRESSURE: MAX Δp 16 BAR
- WORKING PRESSURE: MAX 16 BAR
- VACUUM-TIGHT: UP TO 0.2 BAR ABSOLUTE
DEPENDING ON FLUID TYPE AND TEMPERATURE



MAIN MATERIALS

- BODY: ALUMINIUM (DN50-DN400), GREY CAST IRON, SPHEROIDAL CAST IRON, CARBON STEEL, STAINLESS STEEL, ALUMINIUM - BRONZE
- GASKET MATERIALS: NBR, EPDM, FPM
- DISK: STEEL, STAINLESS STEEL (304, CF8M, 316L), ALUMINIUM - BRONZE
- SHAFT: STAINLESS STEEL, 430F, 316
- O-RING: NBR, FPM
- DISK: STEEL, STAINLESS STEEL (304, CF8M, 316L), ALUMINIUM-BRONZE

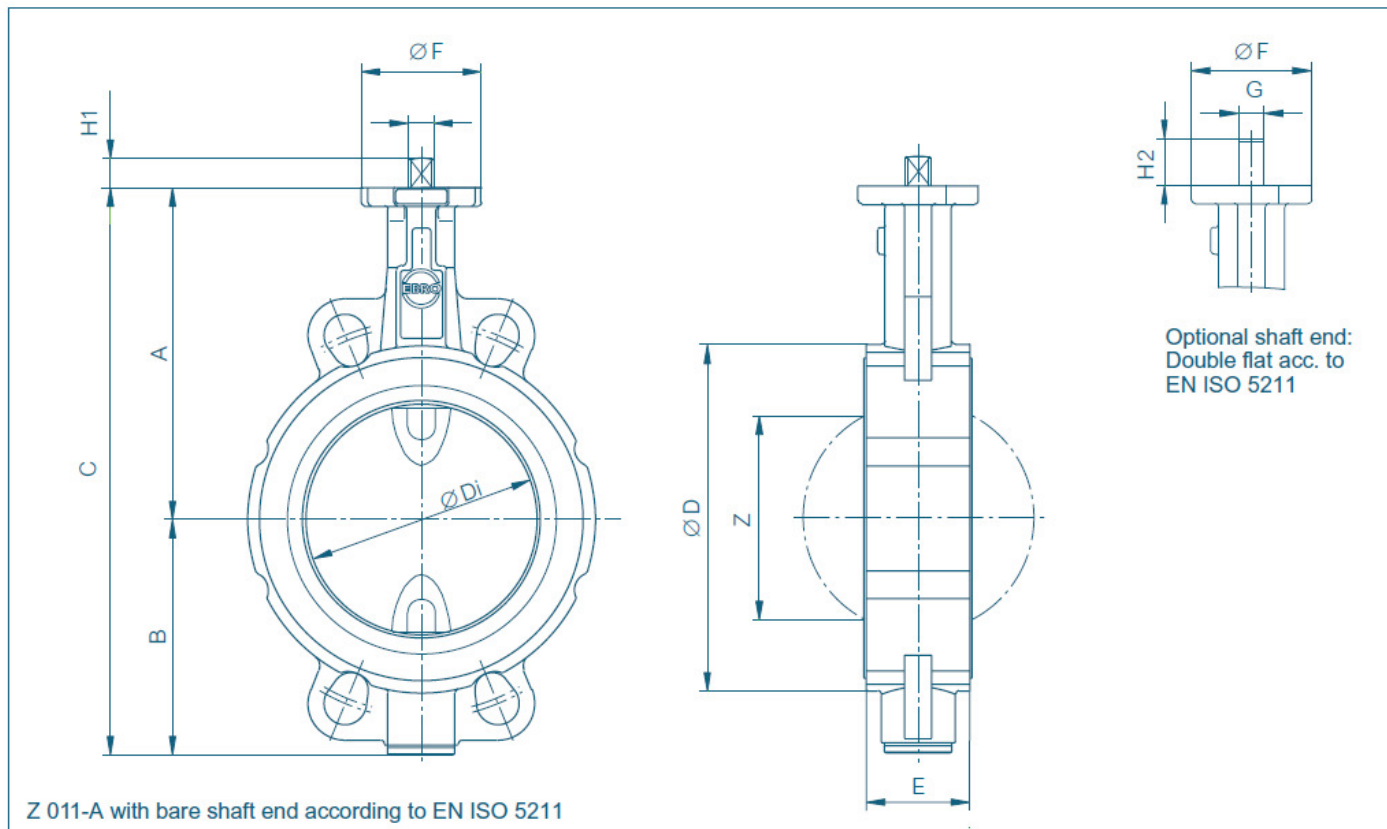

DN [mm]	Size [in]	Dimensions [mm]												Weight [kg] (GG-25)	
		A	B	C	D	Di	E	F	Flange	G	H1	H2	Z	2 Piece Shaft	TS- Shaft
20	3/4	104	45	149	59	31,5	33	54	F04	11	12	19	–	1,3	–
25	1	104	45	149	63	31,5	33	54	F04	11	12	19	–	1,3	–
32	1 1/4	104	50	154	68	31,5	33	54	F04	11	12	19	–	1,4	–
40	1 1/2	113	66	179	80	38	33	54	F04	11	12	19	22	1,8	–
50	2	126	84	210	95	48,5	43	54	F04	11	12	19	25	2,2	–
65	2 1/2	134	93	227	115	63,5	46	54	F04	11	12	19	45	2,9	–
80	3	157	104	261	138	78,5	46	65	F05	14	16	25	65	4,0	4,5
100	4	167	115	282	158	98,5	52	65	F05	14	16	25	85	5,2	5,8
125	5	180	127	307	188	123,5	56	65	F05	14	16	25	111	6,9	7,5
150	6	203	150	353	212	148	56	90	F07	17	19	30	139	9,5	11,0
200	8	228	176	404	268	199	60	90	F07	17	19	30	190	13,2	15,0
250	10	266	212	478	320	248	68	125	F10	22	24	39	240	22,5	25,5
300	12	291	237	528	370	296	78	125	F10	22	24	39	287	31,5	35,0
350	14	332	269	601	408	338	78(92)**	150	F12	*	*	–	330	39,4	45,0
400	16	363	314	677	470	388	102	150	F12	*	*	–	378	58,7	64,5
450	18	397	335	732	530	430,5	114	210	F14	*	*	–	417	91,0	95,5
500	20	437	405	842	574	494,5	127	210	F14/F16	*	*	–	474	107,0	113,5
600	24	498	469	967	675	590	154	300	F16/F25	*	*	–	563	171,0	198,0
700	28	581	507	1088	772	680	165	300	F16/F25	*	*	–	660	251,0	304,0
800	32	630	556	1186	874	780	190	300	F25	*	*	–	757	355,0	375,0
900	36	696	617	1313	973	880	203	300	F25	*	*	–	860	456,0	498,0
1000	40	771	675	1446	1070	980	216	350	F30	*	*	–	956	570,0	718,0
1200	48	880	810	1690	1510	1170	254	350	F30	*	*	–	1154	–	1156,0

* according to the mounted actuator
 ** face to face dim. acc. to EN 558 Tab. 20 (92 mm)

Subject to change without notice.

BUTTERFLY VALVE LUG

TECHICAL FEATURES

- SIZE: FROM DN 20 TO DN 600 (3/4"-24")
- UPPER FLANGE : EN ISO 5211
- TEMPERATURE: - 20°C + 160°C (DEPENDING ON WORKING PRESSURE AND MATERIALS)
- DIFFERENTIAL PRESSURE: MAX Δp 16 BAR
- WORKING PRESSURE: MAX 16 BAR
- VACUUM-TIGHT: UP TO 0.2 BAR ABSOLUTE
DEPENDING ON FLUID TYPE AND TEMPERATURE



MAIN MATERIALS

- BODY: SPHEROIDAL CAST, CARBON STEEL
- GASKETS: NBR, EPDM, FPM
- DISCK: STEEL, STAINLESS STEEL (304, CF8M, 316L), ALUMINIUM - BRONZE
- SHAFT: STAINLESS STEEL 430F, 316
- O-RING: NBR, FPM
- DISCK: SPHEROIDAL CAST IRON, STAINLESS STEEL (CF8M) , ALUMINIUM - BRONZE

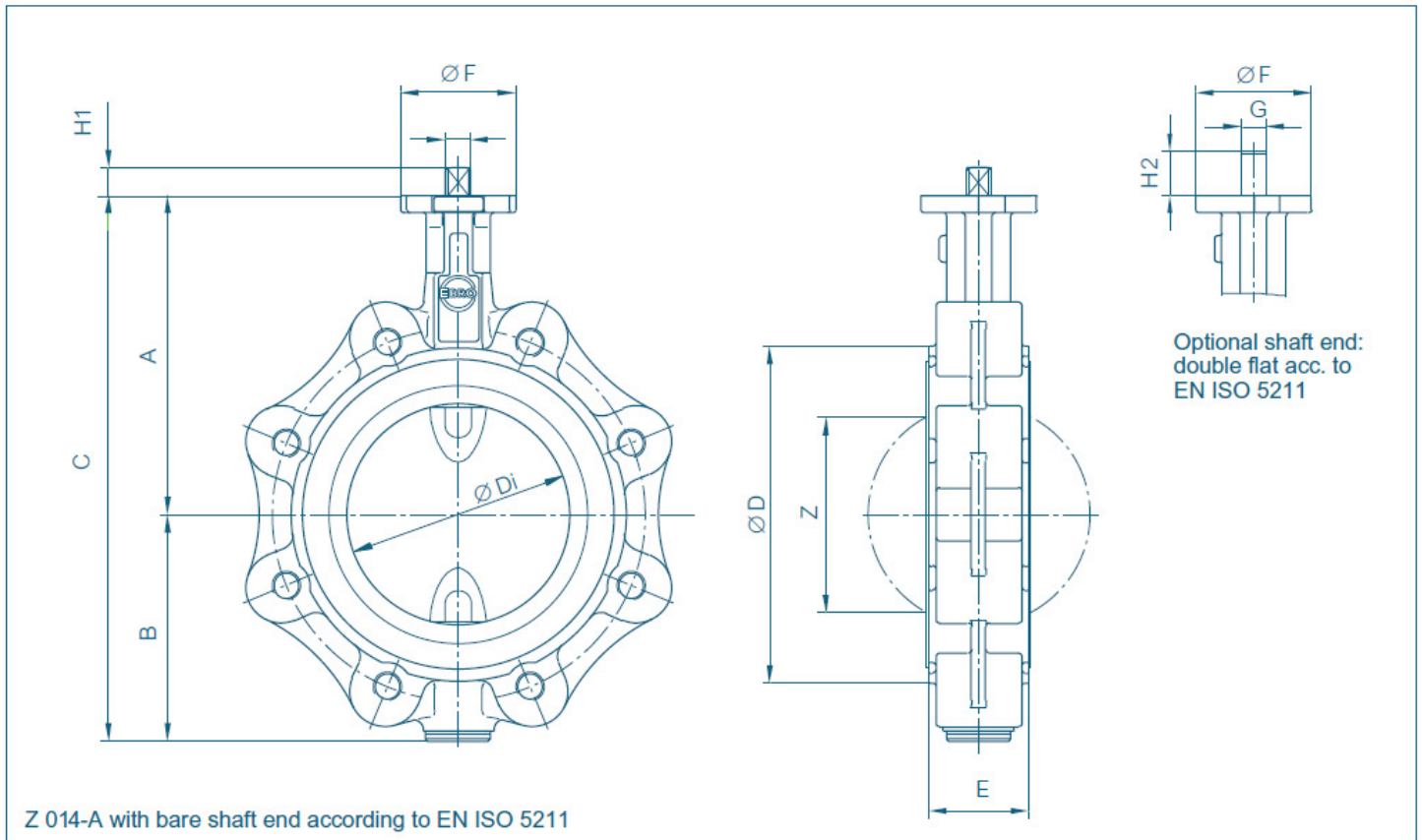

DN [mm]	Size [in]	Dimensions [mm]												Weight [kg] (GG-25)	
		A	B	C	D	Di	E	F	Flange	G	H1	H2	Z	splitted Shaft	TS- Shaft
20	3/4	104	45	149	63	31,5	33	54	F04	11	12	19	–	2,1	–
25	1	104	45	149	63	31,5	33	54	F04	11	12	19	–	2,1	–
32	1 1/4	104	50	154	68	31,5	33	54	F04	11	12	19	–	2,1	–
40	1 1/2	113	66	179	80	38	33	54	F04	11	12	19	22	4,0	–
50	2	126	84	210	95	48,5	43	54	F04	11	12	19	25	4,8	–
65	2 1/2	134	93	227	115	63,5	46	54	F04	11	12	19	45	5,5	–
80	3	157	104	261	138	78,5	46	65	F05	14	16	25	65	8,6	9,1
100	4	167	115	282	158	98,5	52	65	F05	14	16	25	85	9,8	10,4
125	5	180	127	307	188	123,5	56	65	F05	14	16	25	111	10,1	10,7
150	6	203	150	353	210	148	56	90	F07	17	19	30	139	13,1	14,6
200	8	228	176	404	268	199	60	90	F07	17	19	30	190	18,8	20,6
250	10	266	212	478	320	248	68	125	F10	22	24	39	240	29,5	32,5
300	12	291	237	528	370	296	78	125	F10	22	24	39	287	37,0	40,5
350	14	332	269	601	408	338	78(92)**	150	F12	*	*	–	330	54,8	60,4
400	16	363	314	677	470	388	102	150	F12	*	*	–	378	81,5	87,3
450	18	397	335	732	530	430,5	114	210	F14	*	*	–	417	101,4	105,9
500	20	437	405	842	574	494,5	127	210	F14/F16	*	*	–	474	136,3	142,8
600	24	498	469	967	675	590	154	300	F16/F25	*	*	–	563	240,5	267,5

* according to the mounted actuator
 ** face to face dim. to EN 558 Tab. 20 (92 mm)

Subject to change without notice.