

5 WAY – 3 POSITION AIR-FLOW-REVERSING VALVE

VALVOLA A INVERSIONE DI FLUSSO 5 VIE – 3 POSIZIONI

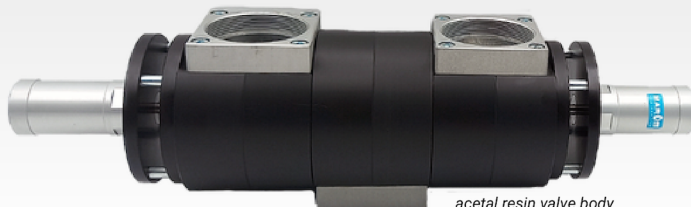

aluminium valve body
corpo valvola alluminio



acetal resin valve body
corpo valvola resina acetica



To be used with blowers
Usò con soffianti



Up to +140° C
Fino a + 140° C

SA



Single acting with electric actuator
Singolo effetto con attuatore elettrico

DA



Double acting with pneumatic actuator
Doppio effetto con attuatore pneumatico

Position 1 Aspiration/gripping
Position 2 Blow/release
Position 3 Standby

Posizione 1 Aspirazione/presa
Posizione 2 Soffio/rilascio
Posizione 3 Standby



Type /Tipo	5-way 3 positions air-flow reversing valve Valvola a inversione di flusso 5 vie 3 posizioni
Sizes/ Misure	1"1/2 – 2" – 2"1/2 – 3" – 4"
Pipe threads/Attacchi	F/F/F gas ISO228
Actuator type /Tipo attuatore	Single Acting /electric) / Singolo Effetto (elettrico) Double Acting (pneumatic actuator) / Doppio Effetto (pneumatico)
Max temperature / Max temperatura	+140°C (based on Maros engineering's test / test Maros engineering)
Ambient temperature / Temperatura ambiente	0/+60°C
Valve body/ Corpo valvola	1" 1/2 -2"-2" 1/2 Anodized aluminium / alluminio anodizzato 3"- 4" Acetal Resin / Resina acetica /
Seal holder/ Otturatore	Alluminio anodizzato /anodized aluminium
Shutter seal / Guarnizione otturatore	FKM
Upon request / Su Richiesta	
Cert. ATEX 1"1/2,2",2"1/2 anodized aluminium body pneumatically driven type only / solo per 1"1/2, 2", 2"1/2 in alluminio anodizzato con attuatore pneumatico	
Valve body in acetal resin for 1" 1/2 -2"- 2" 1/2 /Corpo valvola in resina acetica per 1" 1/2 -2"-2" 1/2	
PTFE shutter seal /Guarnizioni otturatore in PTFE	
2-reed sensor limit switch-box for valve status remote control / Switch-box a 2 sensori reed per il controllo da remoto dello stato della valvola	



Attuatore pneumatico Pneumatic actuator	VI533***	Attuatore elettrico Electric actuator	VI533***24
Cilindro / Cylinder	Alluminio anodizzato /Nylon PA66 Anodized aluminium /Nylon PA66	Voltaggio / Voltage	24 VDC
Pressione di lavoro Pilot pressure	Min. 4 bar – Max 6 bar	Bobina di potenza/ Power Coil	23 A
		Bobina di tenuta / Holding Coil	0.28 A
		Connessioni Elettriche / Electric connections	FASTON

VACUUM VALVES / VALVOLE PER VUOTO

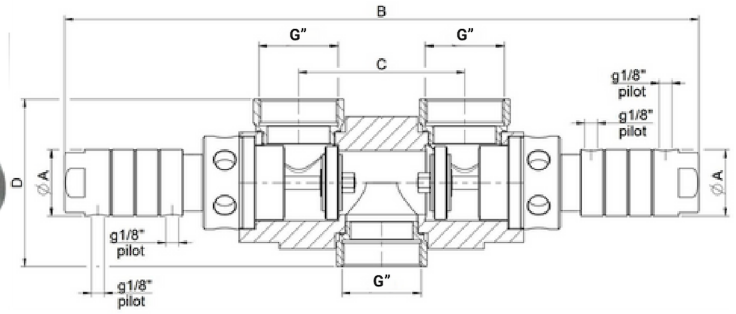
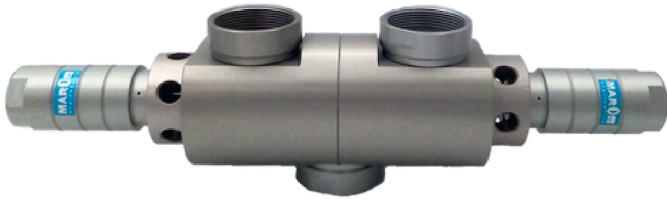

Code Codice	Description Descrizione	Valve body Corpo valvola	Actuator Attuatore	A mm	B mm	C mm	D mm	G"	DN
VI533112	INVA 53 DE 1"1/2	Alluminium	Alluminium	50	478	125	126	1"1/2	40
VI533112NY	INVA 53 DE 1"1/2 NY	Acetal resin	Nylon PA66	42	486	125	126	1"1/2	40
VI53311224	INVA 53 1"1/2 24 VDC	Alluminium	24 VDC	50	526	125	126	1"1/2	40
VI53311224NY	INVA 53 1"1/2 NY 24 VDC	Acetal resin	24 VDC	50	526	125	126	1"1/2	40
VI533200	INVA 53 DE 2"	Alluminium	Alluminium	50	478	125	126	2"	50
VI533200NY	INVA 53 DE 2" NY	Acetal resin	Nylon PA66	42	486	125	126	2"	50
VI53320024	INVA 53 2" 24 VDC	Alluminium	24 VDC	50	526	125	126	2"	50
VI53320024NY	INVA 53 2" NY 24 VDC	Acetal resin	24 VDC	50	526	125	126	2"	50
VI533212	INVA 53 DE 2"1/2	Alluminium	Alluminium	50	478	125	164	2"	65
VI533212NY	INVA 53 DE 2"1/2 NY	Acetal resin	Nylon PA66	42	486	125	164	2"1/2	65
VI53321224	INVA 53 2"1/2 24 VDC	Alluminium	24 VDC	50	526	125	164	2"1/2	65
VI53321224NY	INVA 53 2"1/2 NY 24 VDC	Acetal resin	24 VDC	50	526	125	164	2"1/2	65
VI533300	INVA 53 DE 3"	Acetal resin	Alluminium	50	608	204	157	3"	80
VI53330024	INVA 53 3" 24 VDC (on request)	Acetal resin	24 VDC	60		204	157	3"	80
VI533400	INVA 53 DE 4"	Acetal resin	Alluminium	50	608	204	214	4"	100
VI53340024	INVA 53 4" 24 VDC (on request)	Acetal resin	24 VDC	60		204	214	4"	100

OPERATION CHART / SCHEMA DI FUNZIONAMENTO

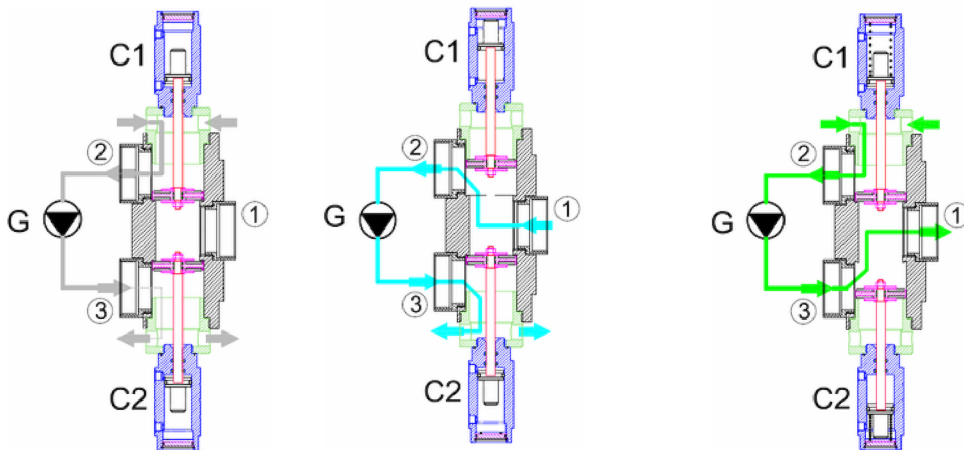

Port 2 is connected to the suction of the blower g, port 3 to discharge and port 1 to final user (e.g. suction cup, tank, etc.)

Operating mode:

Cylinders C1 and C2 both in rest position: passive circulation
 C1 in function and C2 in rest position: suction phase
 C1 rest position and C2 in function: blowing phase

Il raccordo 2 e' collegato all'aspirazione della girante g, il raccordo 3 alla mandata e l' 1 all'utilizzo (es. ventosa, serbatoio, ecc.)

Modalita' di funzionamento:

Cilindri C1 e C2 entrambi a riposo: circolazione a vuoto
 C1 in funzione e C2 a riposo: fase aspirante
 C1 a riposo e C2 in funzione: fase premente

VACUUM VALVES / VALVOLE PER VUOTO